



Main features

- Models 09, 11, 20
- Servo mounting
- Independent linearity up to $\pm 0,05\%$ (standard $\pm 0,5\%$)
- Repetibility $0,01\%$ C.E.T.
- Rotation speed ≤ 600 r.p.m. (within C.E.U.)
- Life duration: $>100 \times 10^6$ operations at 10 r.p.s.
- Infinite resolution
- Electrical terminals: turrets
- Grade of protection IP40
- Suitable for use in explosive environments with presence of gas (groups IIA, IIB, IIC) and combustible powders. Standards for simple device: ATEX CEI EN 50020 2003 - paragraph 5.4 a

TECHNICAL DATA

Model	09 - 11 - 20
Vibrations	5...2000Hz, $A_{max} = 0,75$ mm amax. = 20 g
Shock	50 g, 11ms.
Hysteresis (backlash)	$\leq 15''$ of arc
Electrical terminals	Gold plated turrets
Torque	$\leq 0,20$ Ncm
Rotation speed	≤ 600 giri/min. (within C.E.U.)
Life duration (within C.E.U.)	$>100 \times 10^6$ operations
Tolerance on resistance total	$\pm 20\%$ other values by request
Recommended cursor current	$< 0,1$ mA
Maximum cursor current	10mA
Electrical isolation	$>100M\Omega$ a 500V~, 1bar, 2s
Dielectric strength	< 100 mA a 500V~, 50Hz, 2s, 1bar
Dissipation at 40°C (0W at 120°C)	see table
Actual Temperature Coefficient of the output voltage	$< 1,5$ ppm/°C
Working temperature	-55...+100°C
Storage temperature	-55...+125°C
Case material	Diallylphthalate
Shaft material	AISI 316
Bearings	High precision with double (ZZ) sealed screen in stainless steel
Flange	Anodised aluminium

MECHANICAL DIMENSIONS

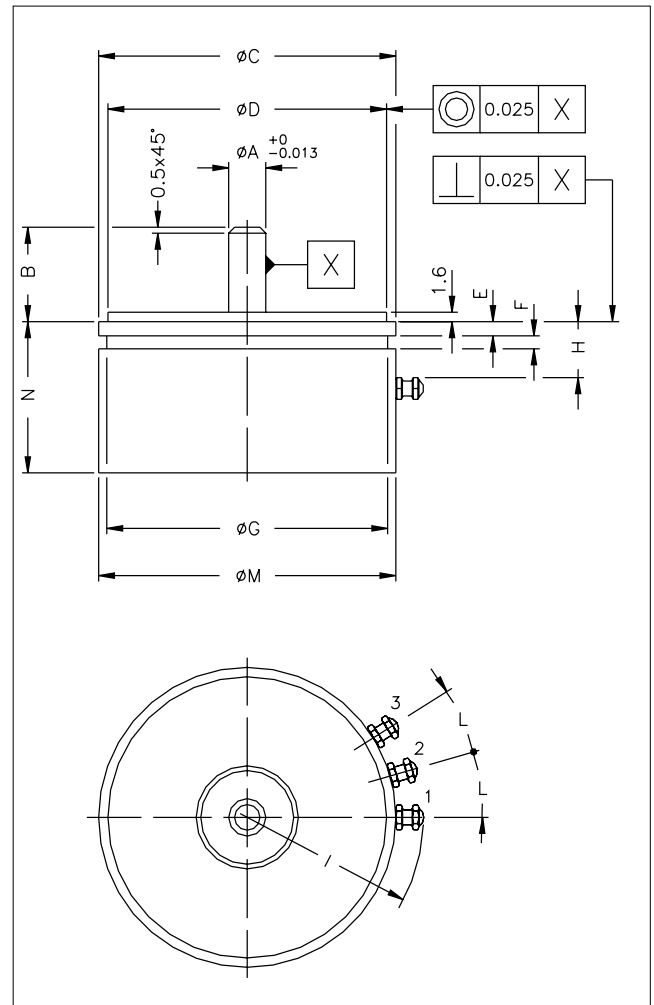

Important: all the data reported in the catalogue linearity, lifetime, temperature coefficient are valid for a sensor utilization as a ratiometric device with a max current across the cursor $I_c \leq 0.1 \mu A$.

MECHANICAL / ELECTRICAL DATA

MODEL		PS09	PS11	PS20
Theoretical electrical stroke (C.E.T.)	°	340 ± 4°	345 ± 4°	350 ± 4°
Useful electrical stroke (C.E.U.)	°		C.E.T. - 2°	
Resistance ± 20% (C.E.T.)	kΩ		1 - 4.7 - 10	
Independent linearity (within C.E.U.)	±%		A = ± 1% B = ± 0,5% C = ± 0,25% D = ± 0,1% E = ± 0,05%	
Dissipation at 40°C (0W at 120°C)	W	1	1,25	3
Mechanical rotation	°		360° continuous	
Weight	g	16	20	90

ELECTRICAL CONNECTIONS

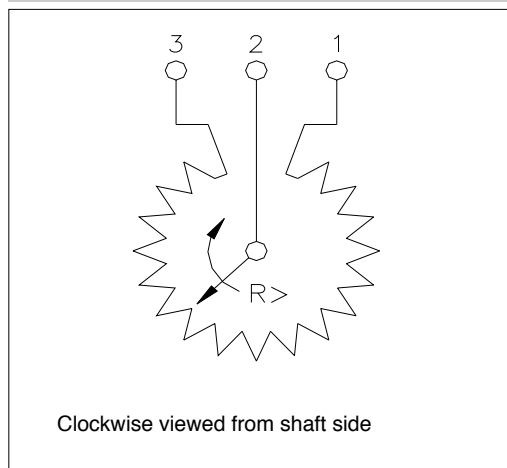

DIMENSIONS

DIMENSIONS (mm)	DESCRIPTION	SIZE/MODEL 09 / PS09	SIZE/MODEL 11 / PS11	SIZE/MODEL 20 / PS20
∅ A + 0/0.013	∅ Stainless steel shaft	3.175	3.175	6.35
B max.	Shaft length	16	16	16
∅ C max.	External ∅ of flange	22.25	27.05	50.8
∅ D	∅ flange Tolerance on flange	19.05 +0 -0.013	24.608 +0 -0.013	47.625 +0 -0.025
E	Shoulder	1.6	1.6	2.4
F min.	Width of groove	1.5	1.5	2.2
∅ G max.	Diameter of groove	20	25	48
H min.	Locating turrets	6	6	10
I max.	Radius on turrets	16	18	30
L ± 2°	Angle between turrets	30°	25°	15°
M max.	External ∅ of case	22.2	27	50.8
N max.	Length for Nr. of elements = 1	21	21	24

MOUNTING DIAGRAM

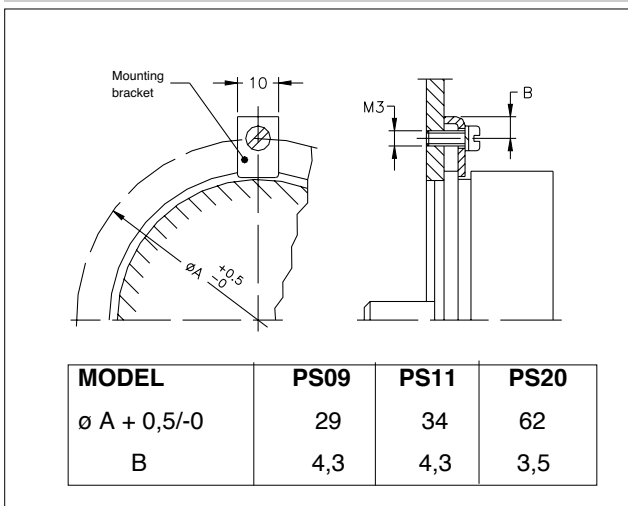

INCLUDED ACCESSORIES

	Code
Fixing kit for PS: 3 brackets, M3x8TC screws, grower	
Rotative transducers PS09 - PS11	PKIT012
Rotative transducers PS20	PKIT013

ORDER OPCODE

Rotative transducer PS

Model

Linearity (std. B)

A = ± 1%
B = ± 0,5%
C = ± 0,25%
D = ± 0,1%
E = ± 0,05%

TAPS (std. 0)

0

Resistance value (std. 103)

1kΩ	102
4,7kΩ	472
10kΩ	103

If requested, it is possible to supply models with non-standard mechanical and/or electrical features

Example: **PS20 - B - 0 - 103**
Rotative transducer model PS20, 1 resistive element, linearity ± 0,5%, no voltage or current intermediate pick-offs, 10kΩ resistance.

GEFRAN spa reserves the right to make any kind of design or functional modification at any moment without prior notice